

## Product Overview

HW-XC511 is the latest single-sided flat antenna radar induction module launched by our company. It has a beautiful appearance, a simple and compact product circuit structure, stable performance, and affordable cost. Its cost-effectiveness is extremely high, especially suitable for the secondary development of intelligent electrical appliances, security products, lighting products, and other electronic fields. This product can be widely used in security monitoring, intelligent control systems, lighting appliances (garage, corridor, road and other places).

## Working principle of the product:

The HW-XC511 microwave sensor module uses a plane millimeter wave horn antenna to transmit and receive high-frequency electromagnetic waves according to the principle of double-transmitter horn Doppler effect. When it detects that there is a slight movement change in the backscatter wave, it triggers the microprocessor to work, and finally outputs a 3V effective high level signal from the OUT terminal.

## Product features:

Low power MCU fixed frequency 10.525G flat antenna design, field shaped signal transmission and reception, wide coverage, high consistency, low power consumption, and ROHS compliance CE KC UL and other certification requirements, and strong anti-interference ability, not affected by temperature, humidity, airflow, dust, noise, brightness, etc. Special anti-interference ability. It can adapt well to the application scenarios of secondary development of the vast majority of intelligent products. This product has better sensing effect when used indoors; When used outdoors, it is normal for the sensing distance to be slightly reduced or the sensitivity to be slightly weak due to the influence of the environment. Users do not need to question the product. This product is mostly used in macro scenarios.

## Induction time:

Default repeatable trigger: if the output signal is triggered for the first time and triggered again in the sensing area, the module delay time will be superimposed again when the first trigger time is not stopped (for example, the module trigger time is 2S, the sensing signal is received again within 2S, and then superimposed again for 2S, and there will always be output signal when the trigger is continuously triggered). Non-repeatable trigger: the induction is triggered once, and the time is not superimposed (for example, the time is 2s, the trigger is once, and the output is 2s. No matter how many triggers are considered invalid within 2s, the time is not superimposed once, and the time is kept for 2s).

## Parameter specification:

Model	HW-XC511	V.01	10.525G fixed frequency module
Input VCC	DC 3.3V-5V / 200mA	DC:V+ (inner7530)	Note: Please pay attention to +and-
Working current I/A	Default 180uA (Reference chart)	Note: Power consumption increases with increasing sensing distance	
Output voltage VOUT	H:3V	L:0V	TTL (1---0)
Induction mode	Doppler movement detection		
Induction time	Time:Default 5s		decided by Software
Sensing distance	SENS:Default 8m	3m-15m	decided by Software
Trigger mode	Repeatable trigger (Default)		
Radiation frequency	1-2s		High level ends, lock and maintain low level for 1-2 seconds
Transmit power	10.525GHz±220MHz		
Angle	0° -180°		decided by MCU-Software
Light sensor	NA		Reserved
working temperature	-20~+80℃		working temperature
Dimensions	L15*W15*D3 mm		Length - width - height/mm
Port	PJ-2.0-5/ 2.54-5pin	V+ OUT GND DA CL	Output terminal (without connector by default)

## Inspection wiring diagram and CAD diagram of the product

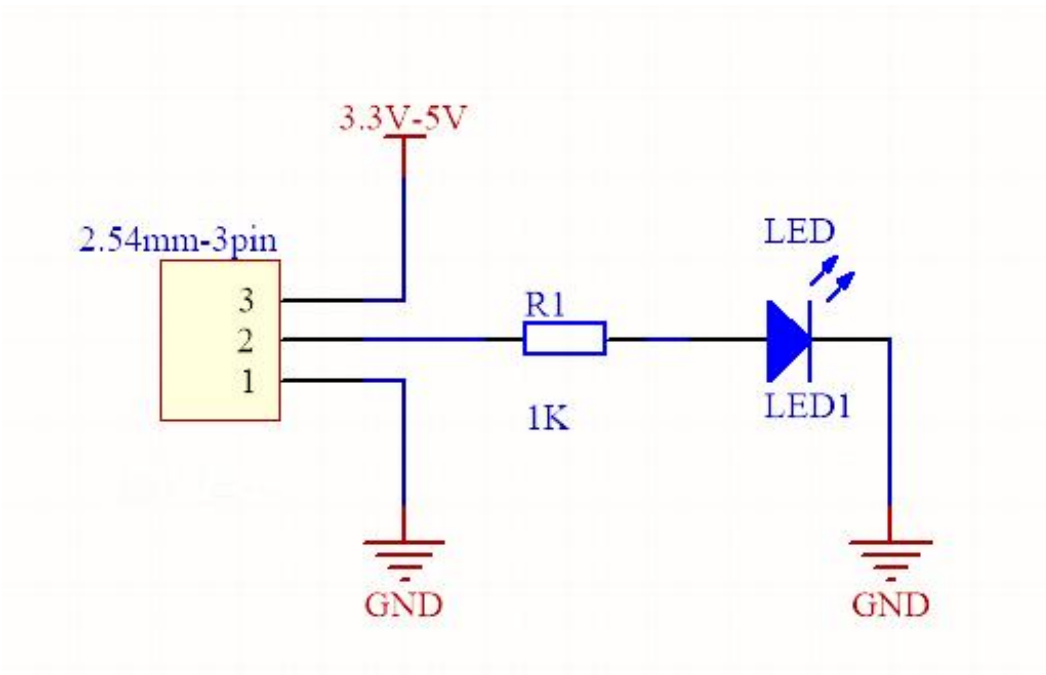

As shown in the figure, VCC can supply DC5V, JP is the output port, 2: the middle output high level signal is 3V, when the two pins output high level, the LED is on, at this time, the LED is on, indicating that the module has signal output. When there is no signal output at pin 2, the output terminal is 0V without signal. If the performance of this product needs to be tested, it can be wired separately according to the above figure. Later, the signal can be used to trigger: trigger circuit - MOS tube - thyristor - relay - MCU, etc.

### CAD dimension drawing:

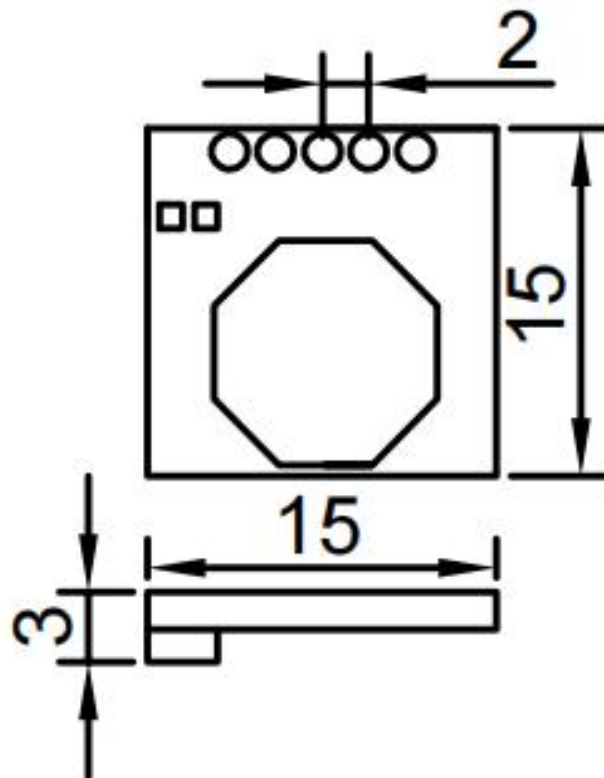

## Angle and radiation diagram

As shown in the figure, the reference figure is obtained from the measuring instrument, and the actual sensing area is based on the indoor angle range of 100 square meters. Due to the close relationship between Doppler radar microwave and space, the actual application needs to define the detection range and angle according to the application environment (the smaller the space of microwave detection range, the higher the sensitivity, and the greater the space, the relative attenuation of the sensitivity). This drawing is for official guidance and reference. The actual application needs to be tested according to the use environment.

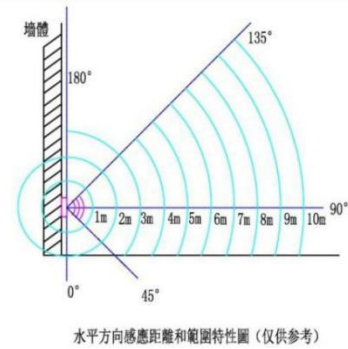
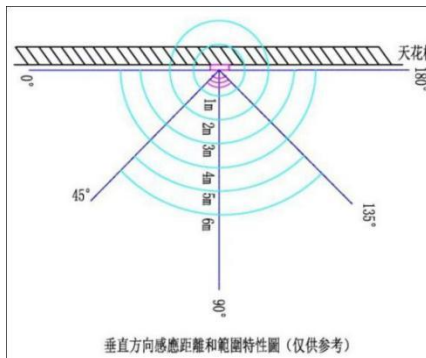
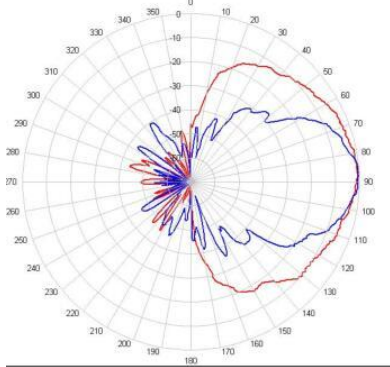

Sample mode	Range of detection area according to Doppler laboratory detection requirements.			Detection area standard	Power consumption corresponding table
	Wall hanging mode			05-12m/1°-130°	
SENS	Wave 1m/0.5s-1s	Walk 2m/0.5s-1s	Dynamic vertical angle	Movement speed	Working current
0.5m	Excellent	Excellent	10° -180°	0.5m/1s	90uA
1m	Excellent	Excellent	10° -180°	0.5m/1s	90uA
1.5m	Excellent	Excellent	10° -180°	0.5m/1s	90uA
2m	Excellent	Excellent	10° -180°	0.5m/1s	90uA
2.5m	Excellent	Excellent	10° -180°	0.5m/1s	90uA
3m	Excellent	Excellent	10° -180°	0.5m/1s	90uA
3.5m	Excellent	Excellent	10° -180°	0.5m/1s	90uA
4m	Good	Excellent	10° -180°	0.5m/1s	90uA
5m	Good	Excellent	10° -180°	0.5m/1s	90uA
6m	-	Excellent	10° -180°	0.5m/1s	90uA
6.5m	-	Excellent	10° -180°	0.5m/1s	90uA
7m	-	Excellent	10° -180°	0.5m/1s	180uA
8m	-	Excellent	10° -180°	0.5m/1s	180uA
10m	-	Excellent	10° -180°	0.5m/1s	1mA
11m	-	Excellent	10° -180°	0.5m/1s	1mA
12m	-	Excellent	10° -180°	0.5m/1s	1mA
15m		Good	10° -180°	0.5m/1s	1mA

 Product physical drawing:

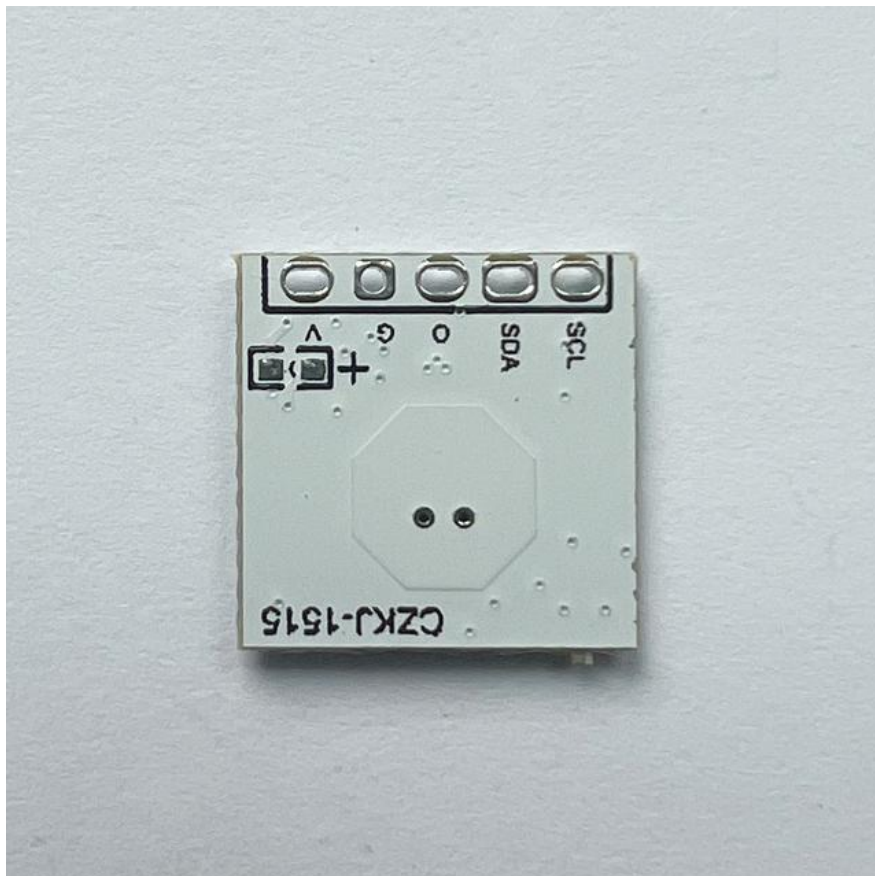
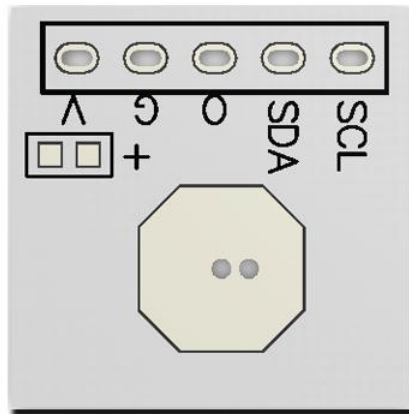

## Attention:

### 1.Requirements for product installation process

During product installation test and actual assembly, be sure to keep at least 10mm space in front of the antenna board (S-shaped perforated PCB) of the module product, and never close to or touch the plane of any object, otherwise the product cannot work normally.

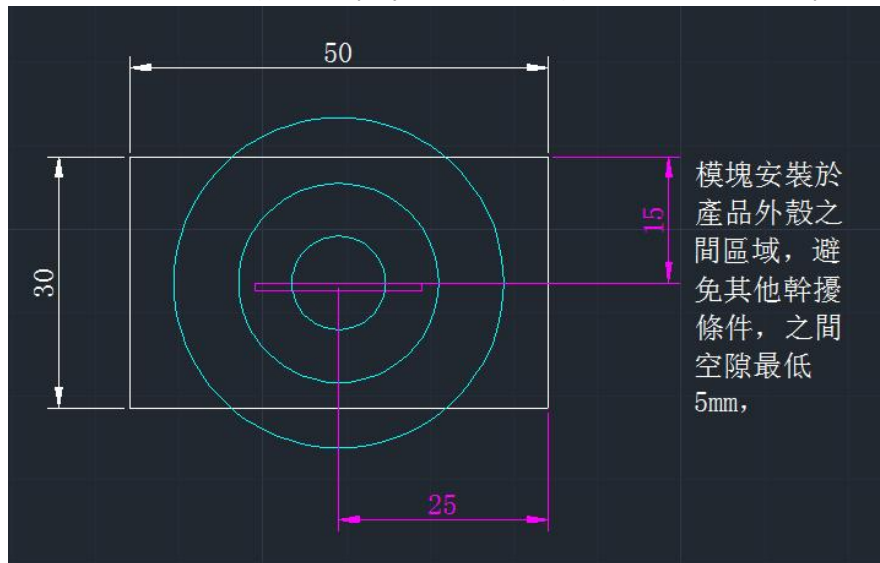

### 2. About power supply

It is recommended to use qualified DC stabilized power supply, that is, DC stabilized power supply with output voltage, current and ripple coefficient up to standard, otherwise the stability of the product will be affected, and some abnormalities may occur, such as false alarm, no induction, cycle self-start, etc.

### 3.About false positives

1. To ensure the qualification of the power supply, please refer to the first item above;
2. During the test, ensure that there are no moving objects around the product to be tested (within the sensing range);
3. There is about 5s initialization time after power-on. During this time, it is abnormal induction, which may cause false alarm; Determined by TIME;
4. In the indoor test, the sensing is relatively sensitive, and the surrounding should be kept static, and the next test should be carried out after the end of the first sensing signal cycle;

During outdoor testing, be sure to pay attention to the dynamic conditions of the surrounding environment, such as birds, pedestrians, vehicles, etc;

5. The signal current output by this module is very weak. When directly driving the load, it will also cause false alarm. Please refer to the application diagram of this product for connection.

### 4.Adjustment of working delay

A [time] resistor TIME is welded on the front of the module to change the delay time (Please contact relevant staff if VR is not required).

### 5.Adjustment of sensing distance

There is a [distance] resistor SENS on the front of the module to change the inductive distance (If VR is not required, please contact relevant staff.

### 6.Shell assembly of this product

The metal shell is not easy to be penetrated by microwave and infrared ray, so this product should not be installed in the metal shell for use. However, obstacles such as plastic, ceramic and woody soil have good penetration effect. Please refer to the test for details.

### 7.Mutual harmony of this product

This product has certain mutual resonance interference, so within the effective sensing range, try to avoid installing two or more modules face to face, otherwise, it may affect your use effect. If necessary, please be sure to contact our relevant staff.

## About the manufacturer - ShenZhen HaiWang Sensor Co., Ltd

ShenZhen HaiWang Sensor Co., Ltd is a high-tech enterprise integrating research and development, production, sales and after-sales service. It has focused on infrared and microwave induction technology for more than ten years. We are specialized in providing various sensor components, sensitive electronic devices, intelligent electronic devices and other series of products, such as pyroelectric infrared probes and their supporting IC and Fresnel lenses; Infrared sensing module; Microwave induction module; Audio player, and can provide product technical development and design, customized processing, and technical support. Our products are widely used in lighting, public security, advertising media, traffic safety, etc.

Please identify our brand [HW].

ShenZhen HaiWang Sensor Co., Ltd